

# GMRC Engine Analyzer Workshop

San Antonio, Texas  
July 2022

# Balancing Slow Speed Reciprocating Engines

The Old and The New  
July 2022



Jim McCoy, Radical Combustion Technologies, LLC



Bryan Stewart, Machinery Monitoring Systems, LLC



**To begin my presentation,  
I would like to review how we got  
where we are!!**

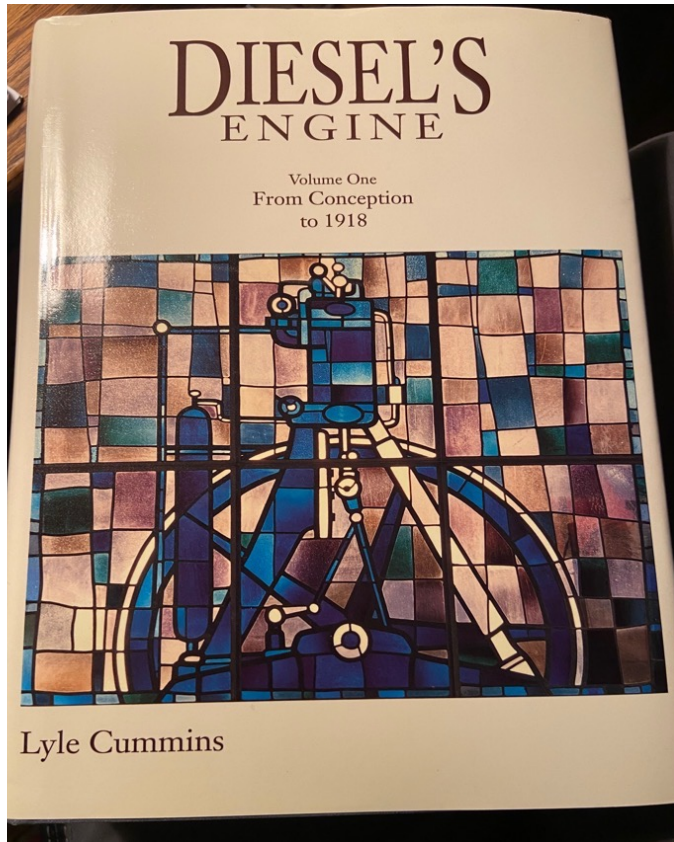

# *Historical Balancing Methods*

Great Book!!

# Historical Balancing Method

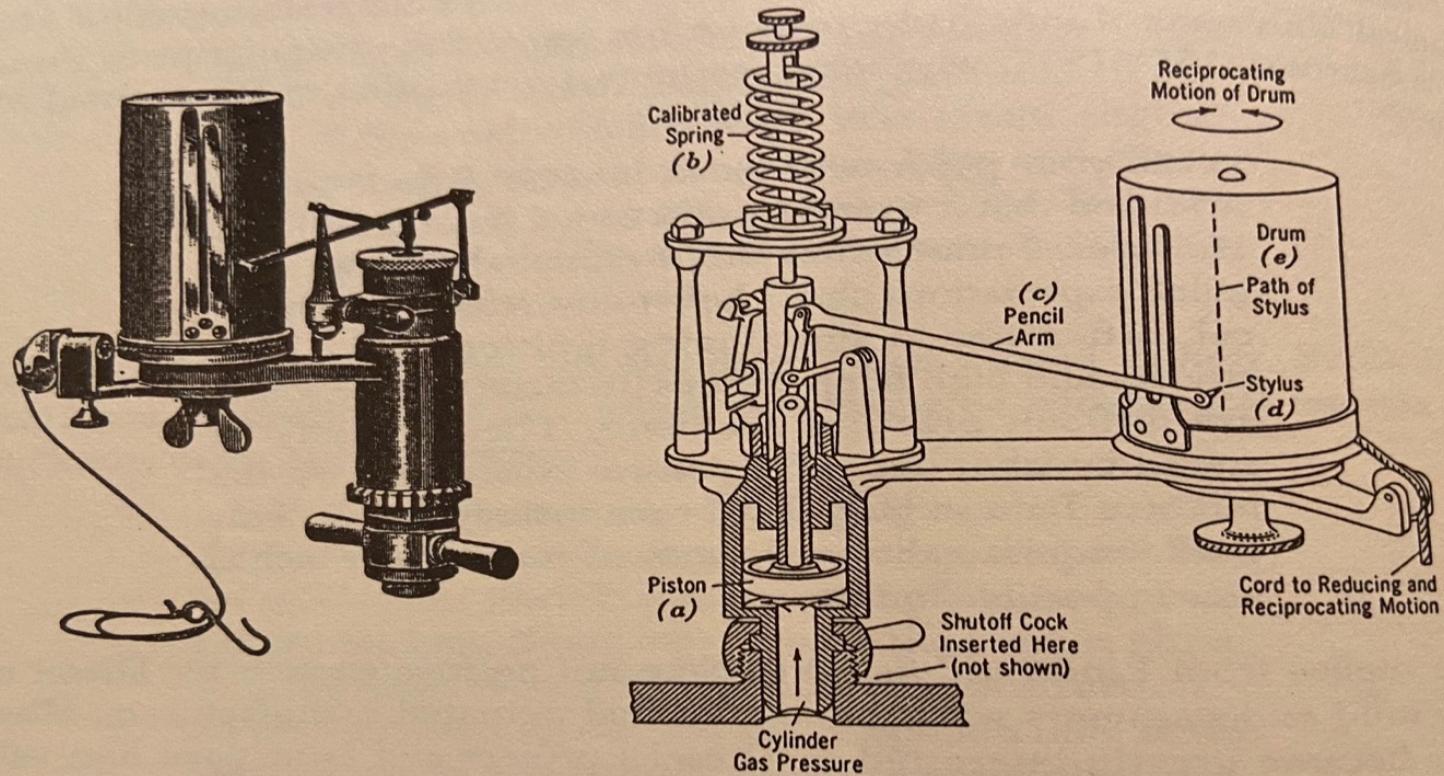

Fig. 3-4. Indicator for making a P-V diagram (indicator card). A pressure trace is made on paper wound on the drum as piston movement turns the drum. This provided a record of the cylinder pressure at each point in the piston stroke. (*Hawkins' Indicator Catechism*, 1903)

worry about how to "fatten" his diagram. But he had to be satisfied with the



**The first traces from the device  
when Rudolf Diesel first ran his  
engine in 1895!!**

# First traces from Rudolf Diesel, 1895

Fig. 6-5. First indicator diagrams, burning gasoline, when 2nd redesign of engine was run, April 29, 1895. (*Die Entstehung...*)

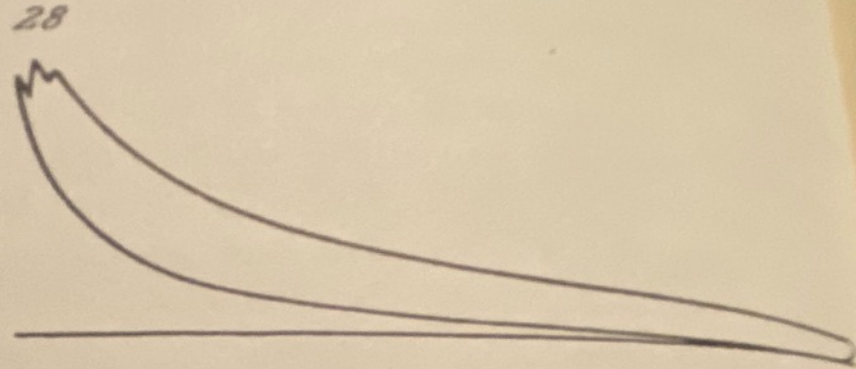

Fig. 6-6. 1st Indicator diagram burning kerosene, taken May 30, 1895, with 2nd design of engine. (*Sass, Geschichte...*)



Gillhausen of Krupp witnessed the May 1895...  
did Krupp) to use...



Rudolph Diesel

- In 1897 demonstrated a 25 HP, 4-stroke, single cylinder engine
- Fueled with peanut or vegetable oil
- By 1912, more than 70,000 diesel engines around the world
- In 1913, he disappeared from the Steamship Dresden while traveling from Antwerp, Belgium to Harwich, England
- Officially, deemed suicide by drowning

#### Conspiracy Theories

- “Inventor thrown into sea to stop sale of patent to British Government”
- “Murdered by agents from big oil trusts”
- “Murdered by coal industrialists”



Leutert MSI-3 EPPI  
(Circa 1940)



# Electronics Evolve

Beta-Trap

Windrock 6310 CA

Windrock Autobalance™

MMS Snapshot®

Hoerbiger/Cooper Hyperbalance III™

MMS ProBalance® / ProBalance® Plus

# Safety

Always complete a Job Safety Analysis (JSA) before entering the work area. It should include but not be limited to:

- Hazardous atmosphere
- Toxic chemicals
- Flammable gases and liquids
- Low headroom
- Slips, trips, or fall hazards
- Extreme surface temperatures
- High pressures
- Pinch points, rotating parts
- Overexertion
- Poor visibility, weather, noise
- Required PPE condition

# Engine Data Collection

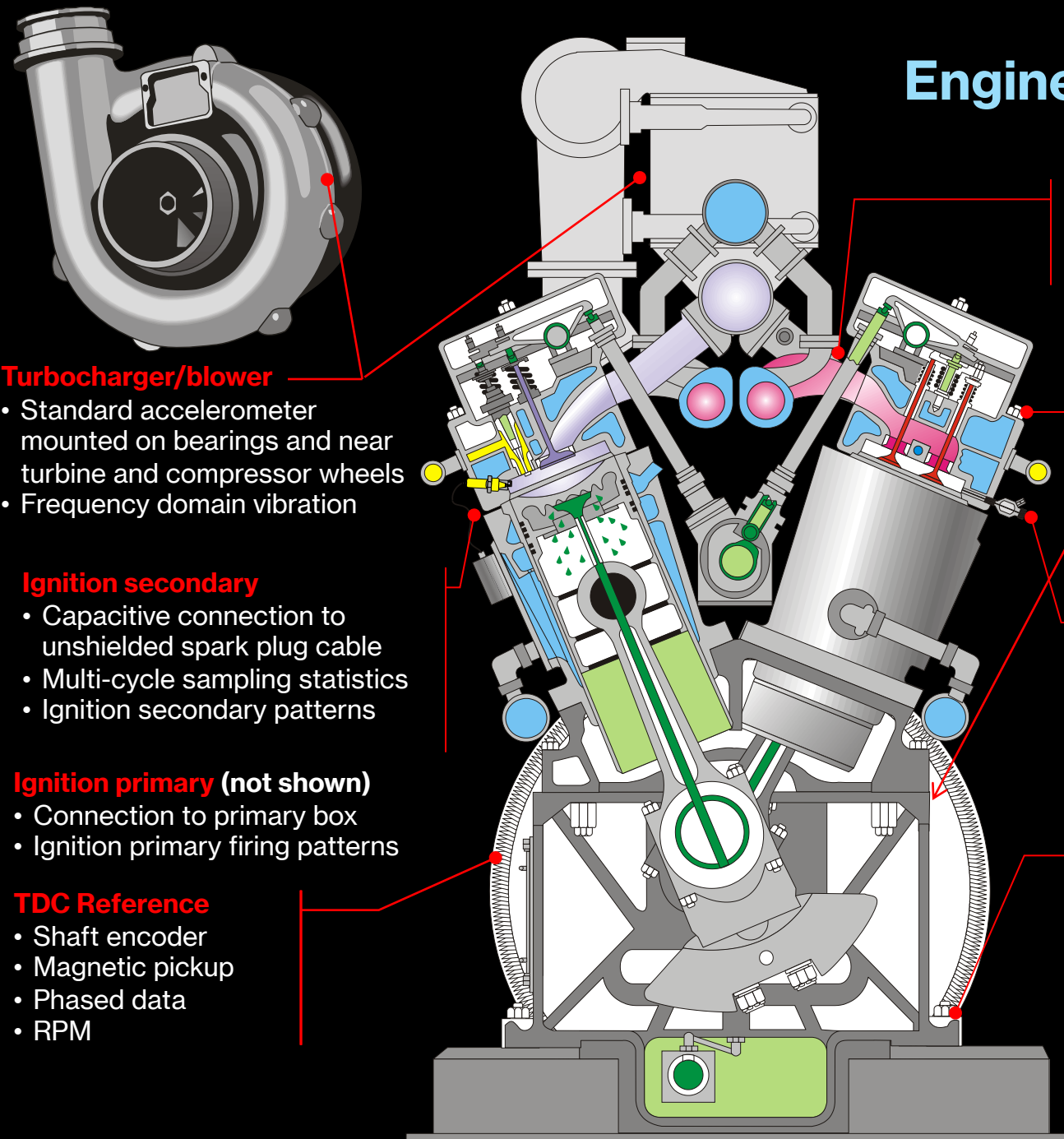

## Turbocharger/blower

- Standard accelerometer mounted on bearings and near turbine and compressor wheels
- Frequency domain vibration

## Ignition secondary

- Capacitive connection to unshielded spark plug cable
- Multi-cycle sampling statistics
- Ignition secondary patterns

## Ignition primary (not shown)

- Connection to primary box
- Ignition primary firing patterns

## TDC Reference

- Shaft encoder
- Magnetic pickup
- Phased data
- RPM

## Cylinder exhaust temperatures

- Infrared temperature wand
- pyrometer

## Cylinder, valve, wrist pin and bearing vibration

- Ultrasonic microphone
- Standard accelerometer
- Time domain data phased to crankshaft position

## Cylinder pressure

- Pressure transducer
- Time domain data phased to crankshaft position
- Peak pressure statistics

## Frame vibration (displacement)

- H, V, A taken at various locations on engine frame
- Both Time & Frequency domain data

# Engine Concerns

- Ignition
- Fuel
- Combustion
- Mechanical condition
- Lubrication
- Cooling

# The Two-Stroke Engine

- The complete combustion cycle (compression, power, exhaust and intake) is accomplished in one revolution of the crankshaft
- Portions of both the intake and exhaust processes (**scavenging**) are accomplished at the end of the power stroke and the beginning of the compression stroke
- The fuel valve cam is driven at engine speed
- Can not be naturally aspirated

# Sequence of events for a 2-stroke engine

PT: start of cycle

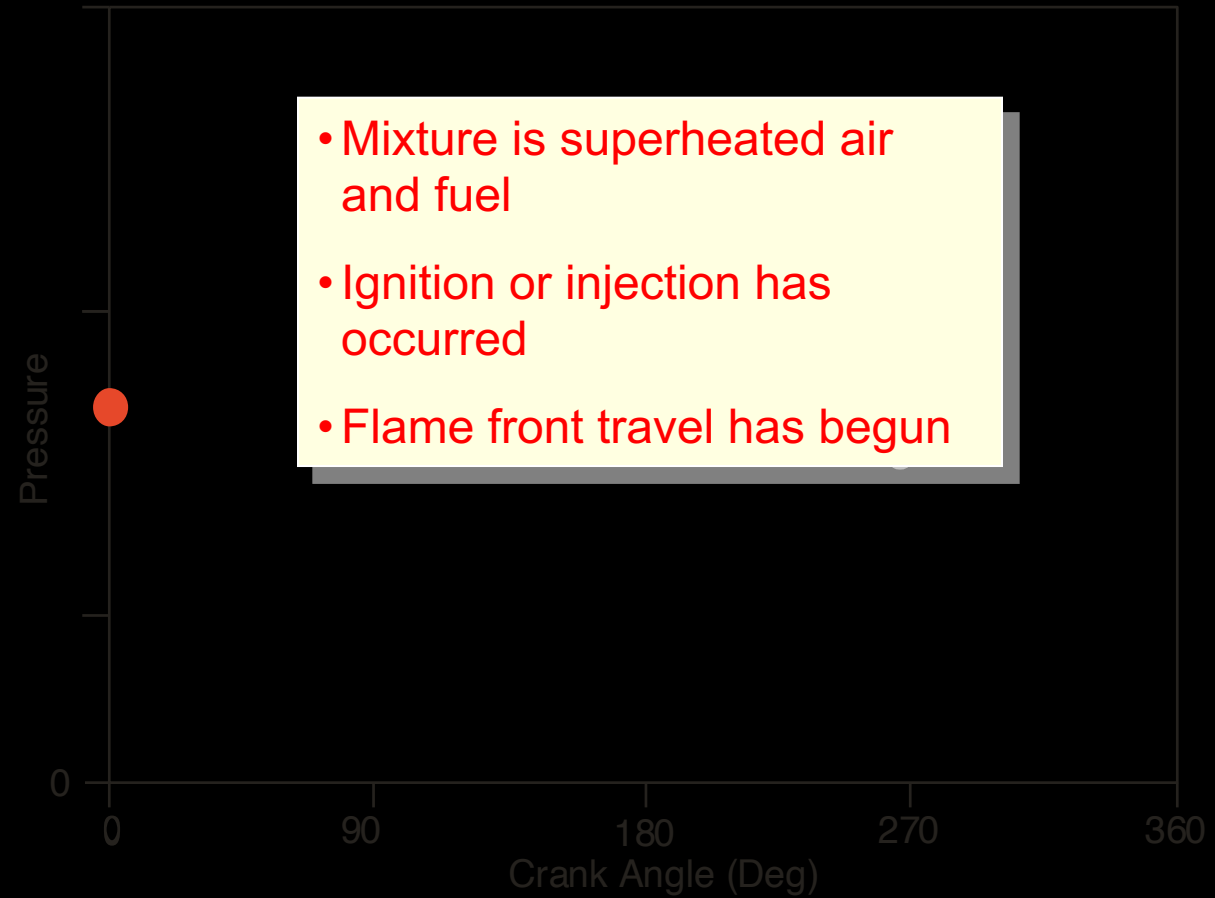
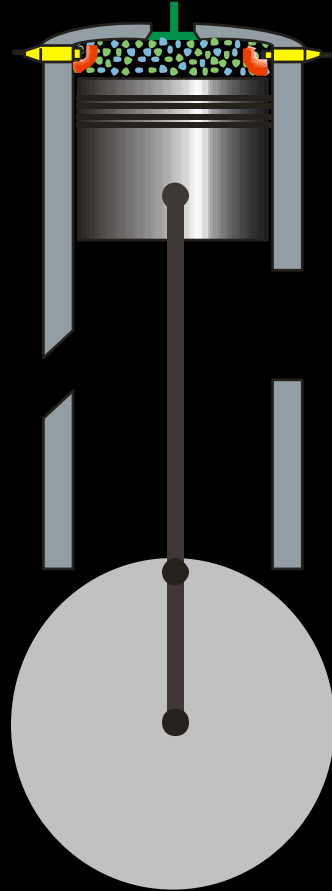

# Sequence of events for a 2-stroke engine

## PT: combustion

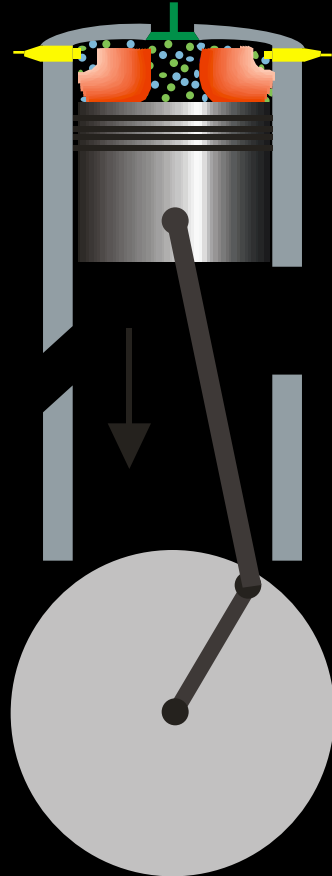

Pressure

0

0

- Flame travels through chamber
- Heat is released, pressure rises
- Temperature at flame front is about 3500°F
- Peak occurs 15-20 deg ATDC
- Speed of propagation is critical
  - Too fast, detonation
  - Too slow, soft fire

90

180

270

360

Crank Angle  
(deg)



# Sequence of events for a 2-stroke engine

PT: power

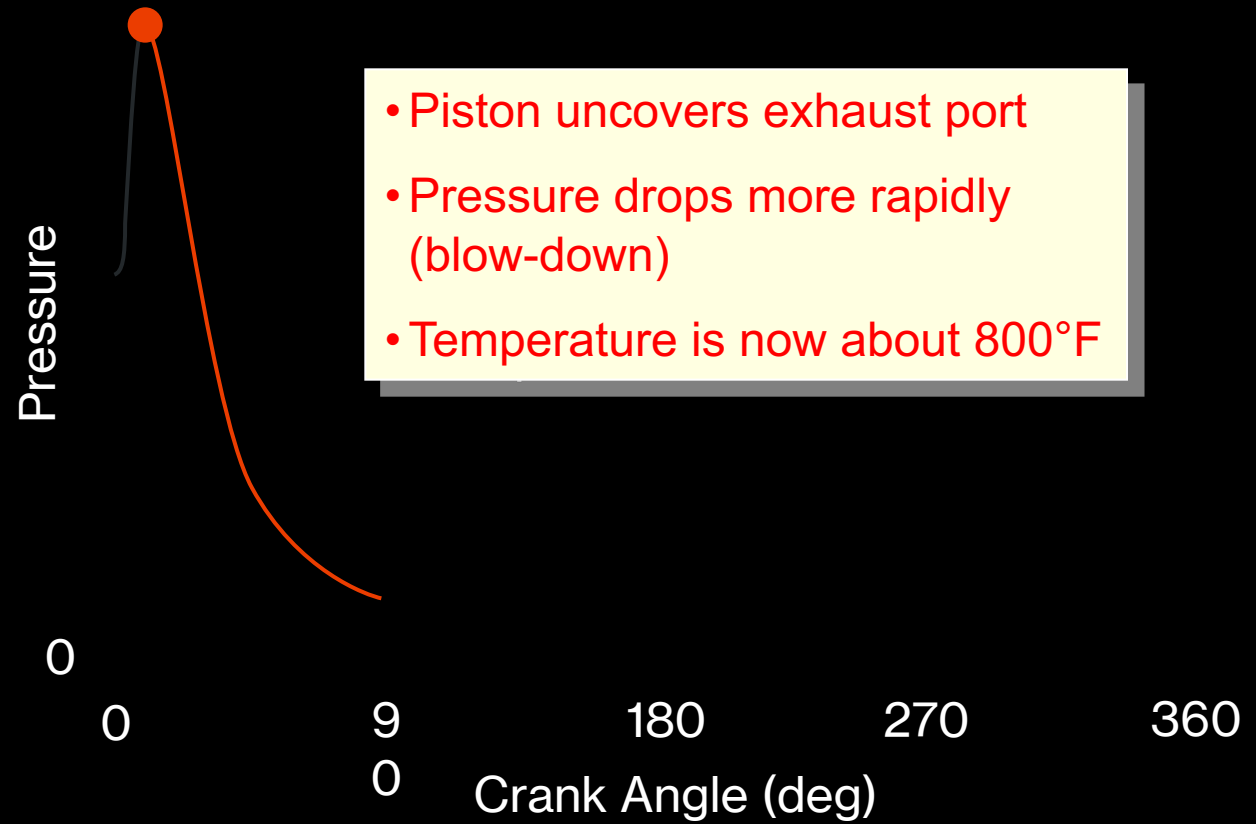
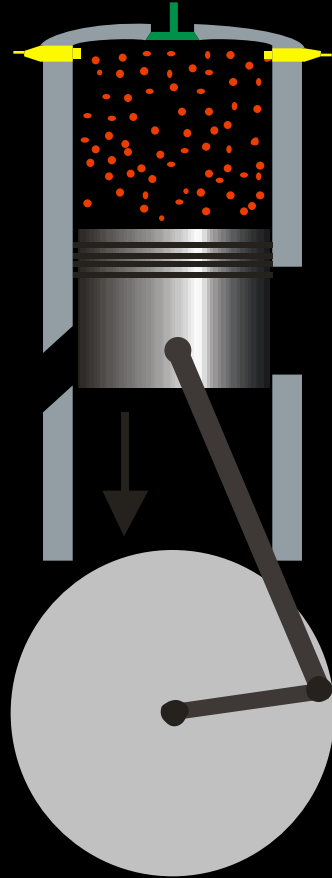

# Sequence of events for a 2-stroke engine

## PT: exhaust blowdown

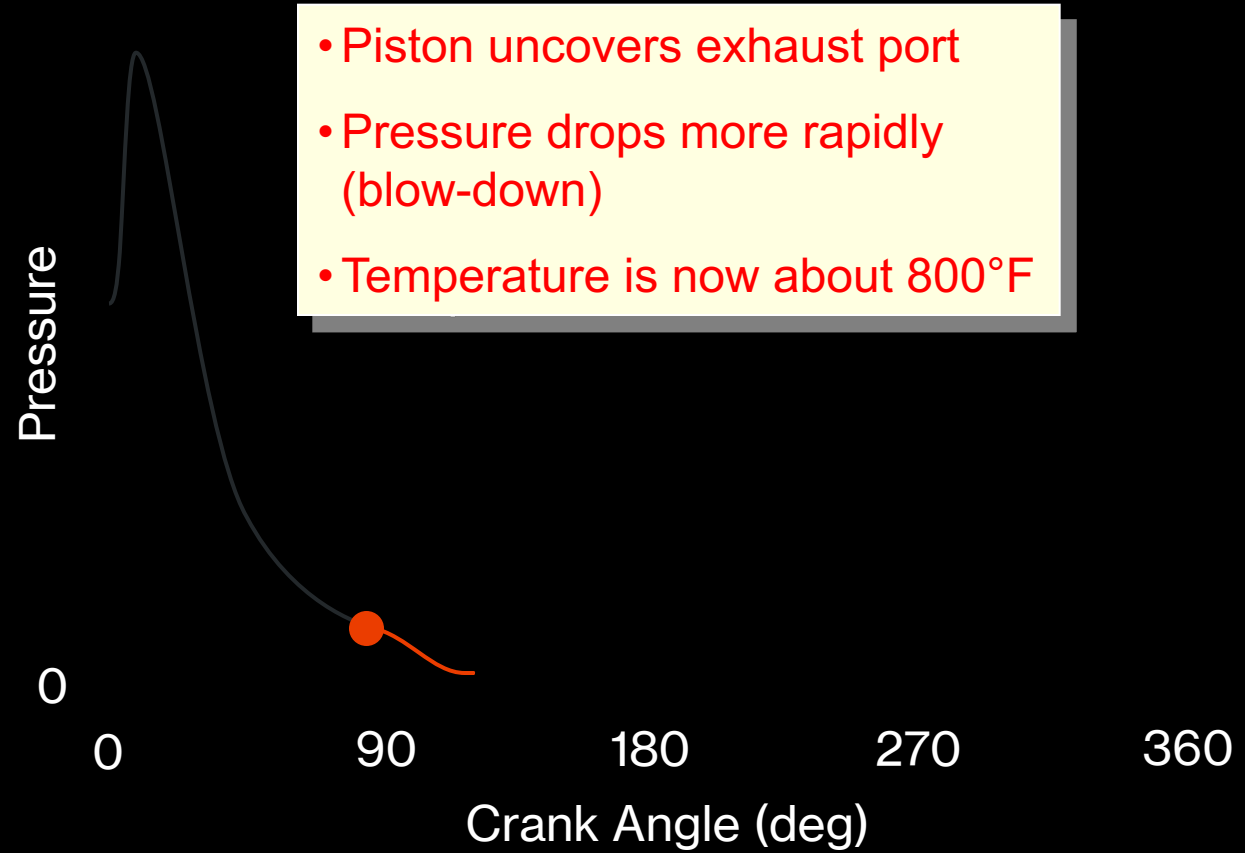

# Sequence of events for a 2-stroke engine

## PT: air intake

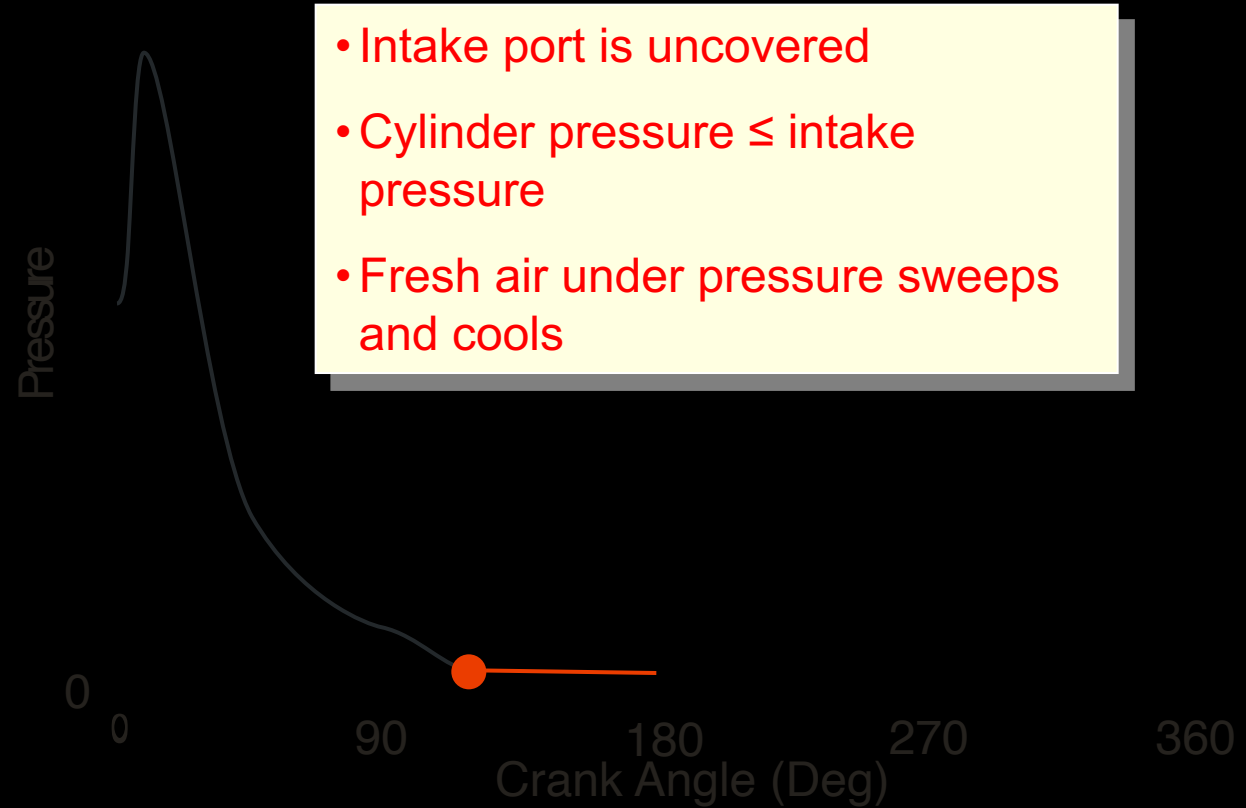
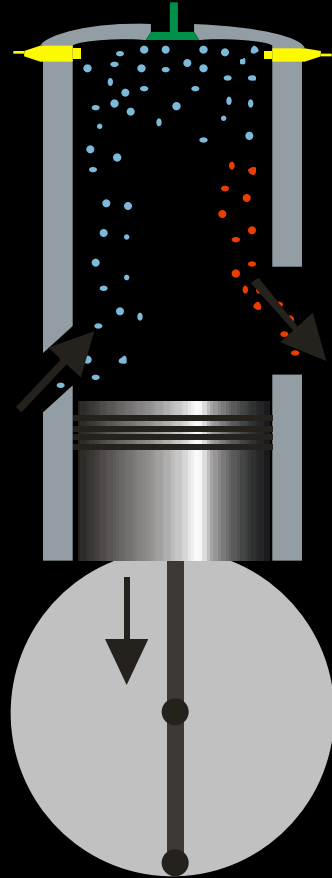

# Sequence of events for a 2-stroke engine

## PT: scavenging

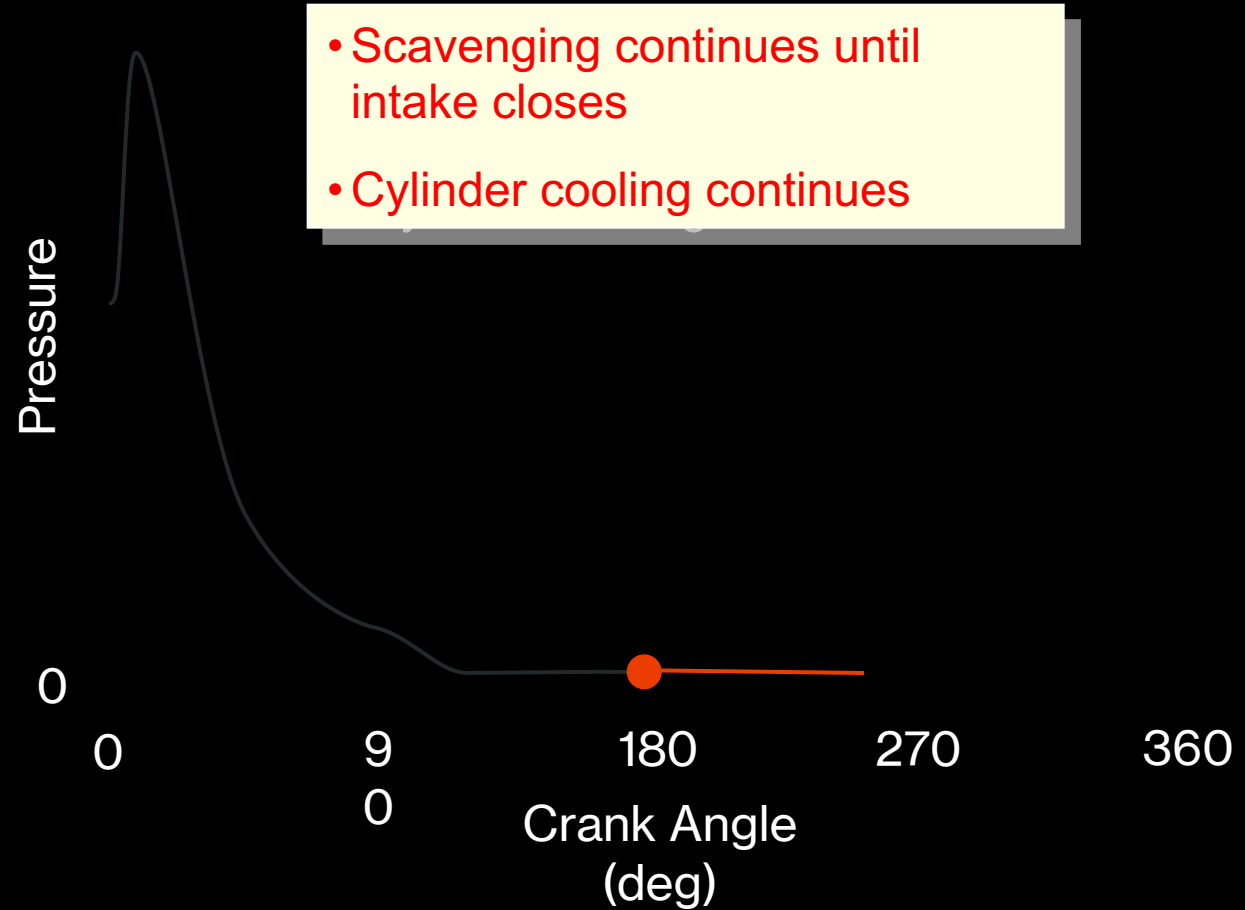
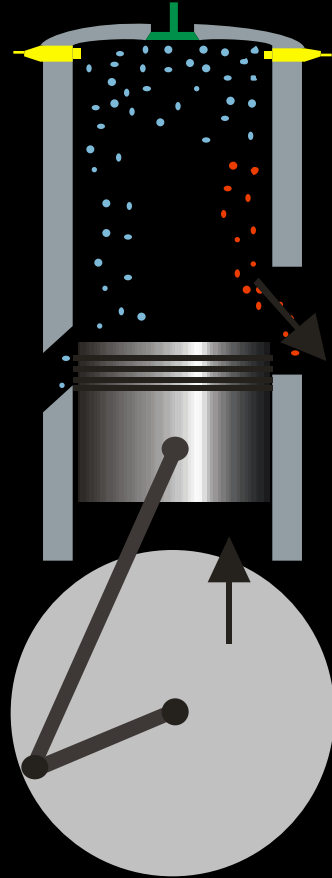

# Sequence of events for a 2-stroke engine

## PT: fuel intake

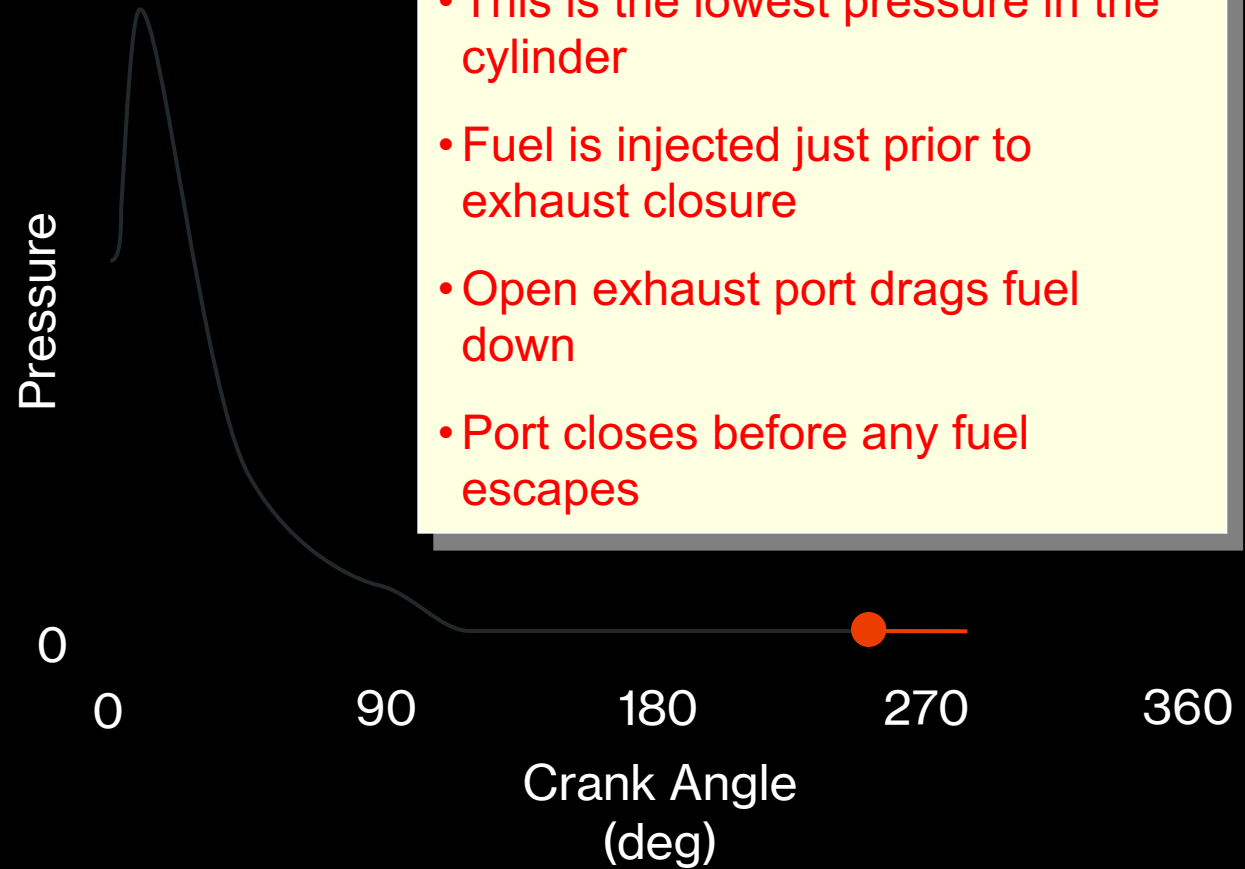
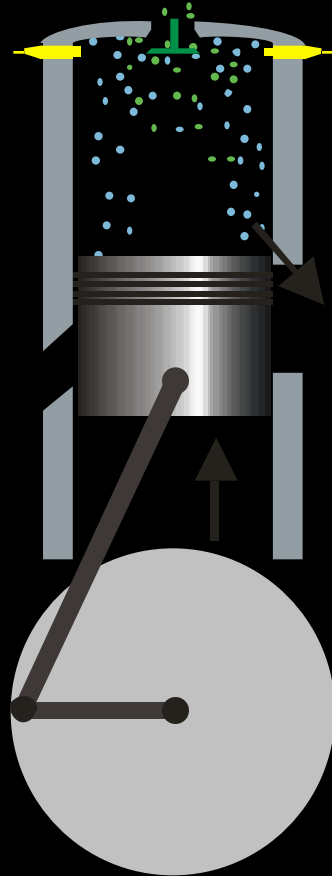

- Scavenging continues until intake closes
- This is the lowest pressure in the cylinder
- Fuel is injected just prior to exhaust closure
- Open exhaust port drags fuel down
- Port closes before any fuel escapes

# Sequence of events for a 2-stroke engine

## PT: compression

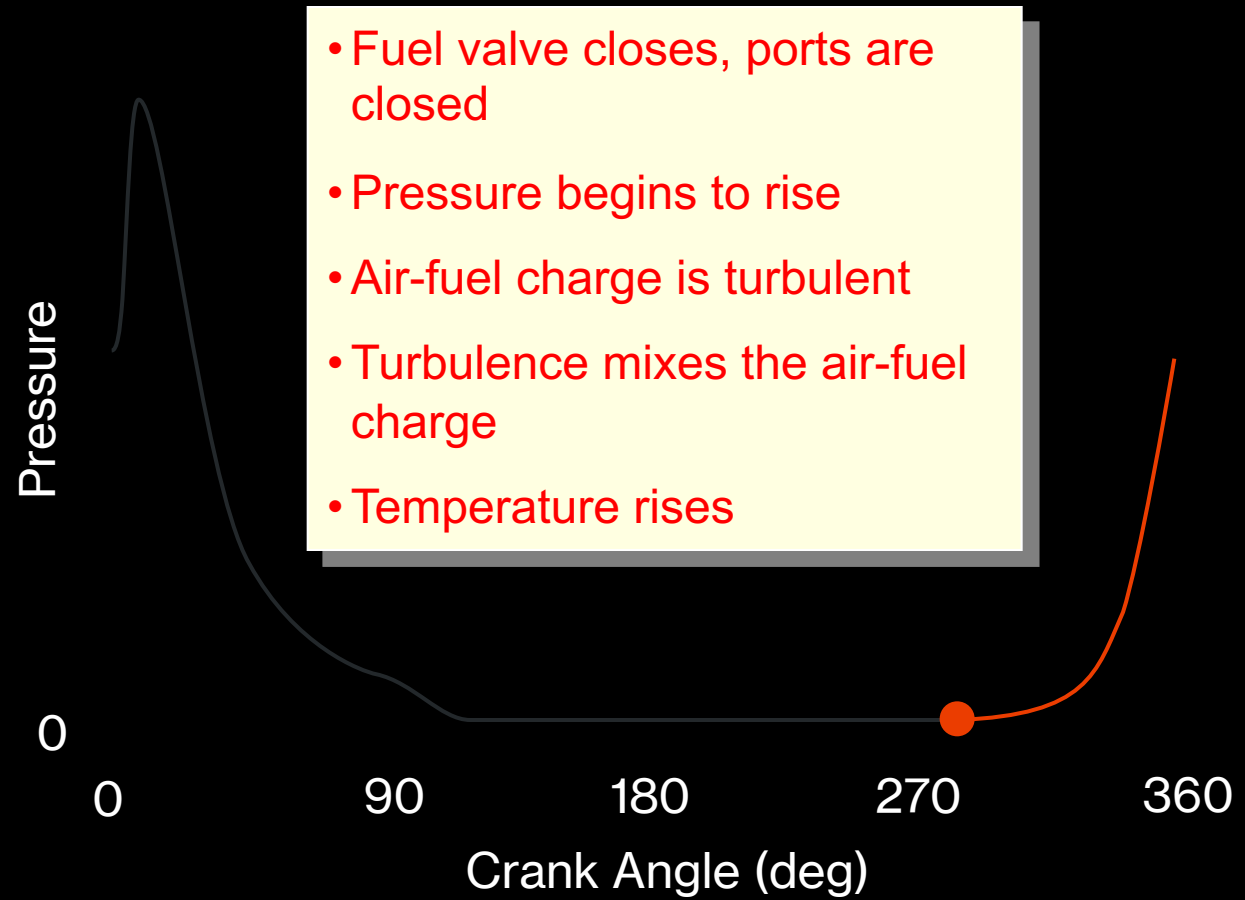
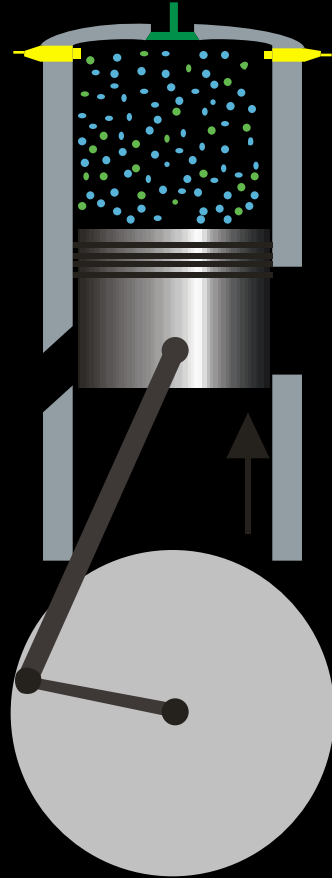

# Sequence of events for a 2-stroke engine

## PT: ignition

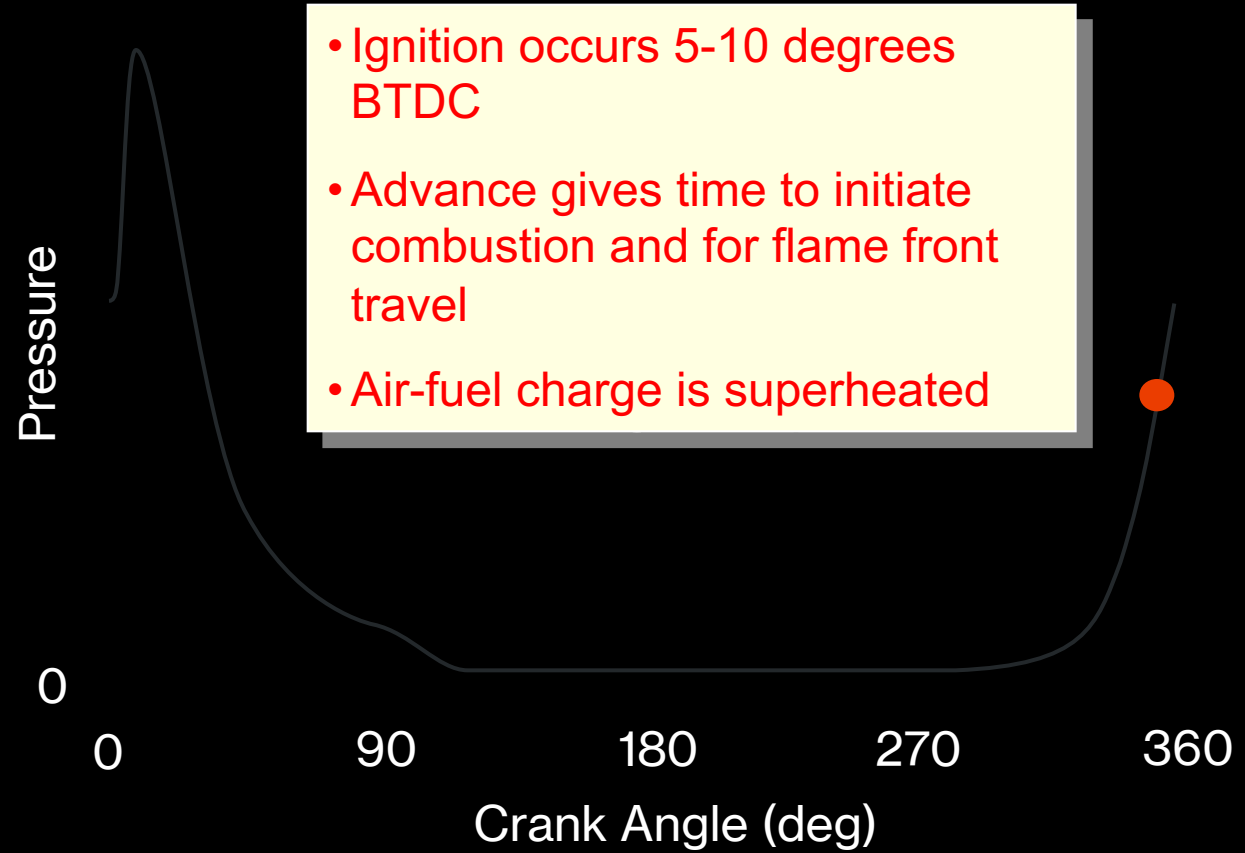
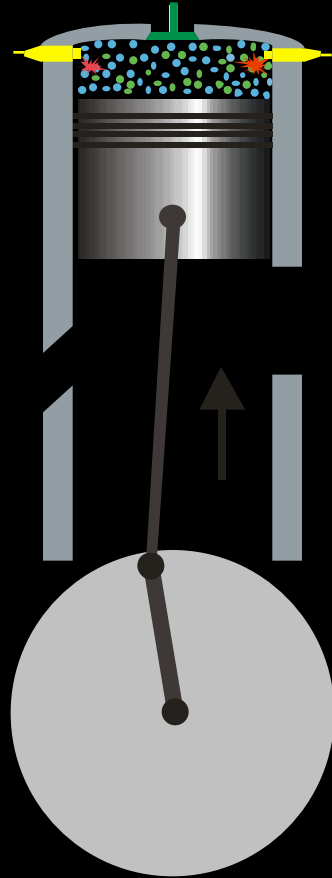

# Sequence of events for a 2-stroke engine

PT: end of cycle

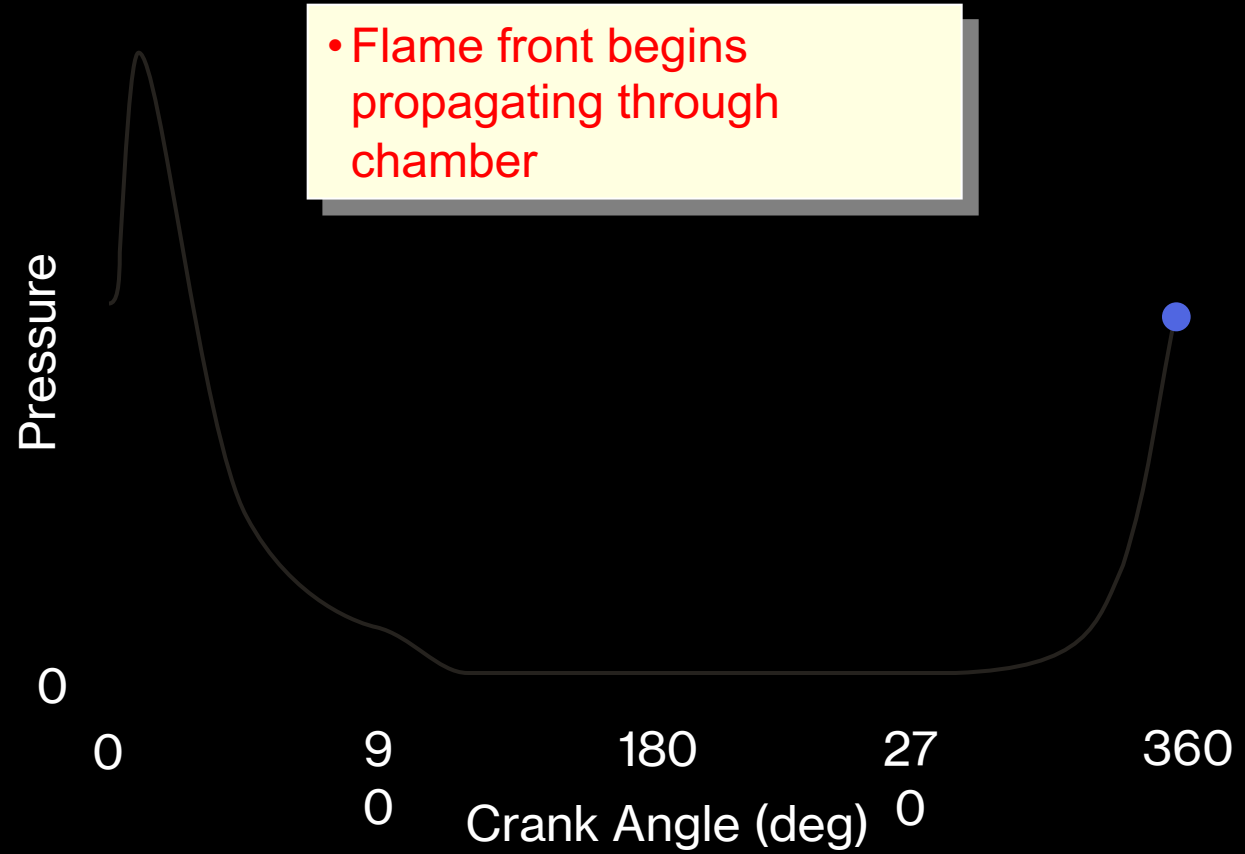
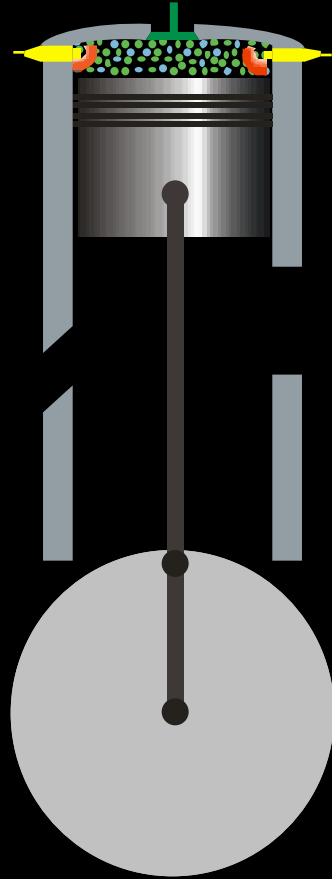



# 2-Stroke Pressure Parade

Averaged Pressure Trace

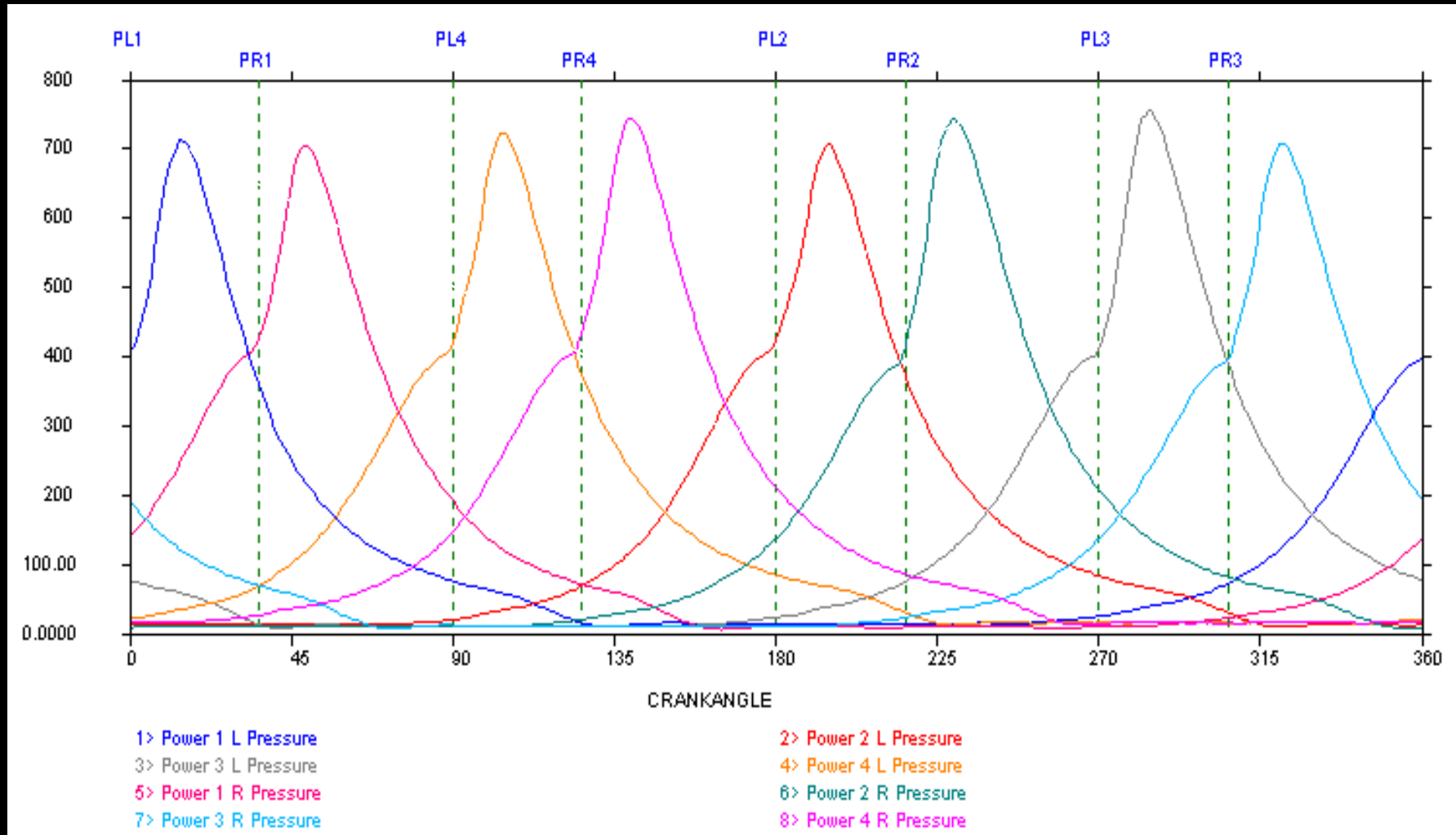

# 2 Stroke Scavenged Engine

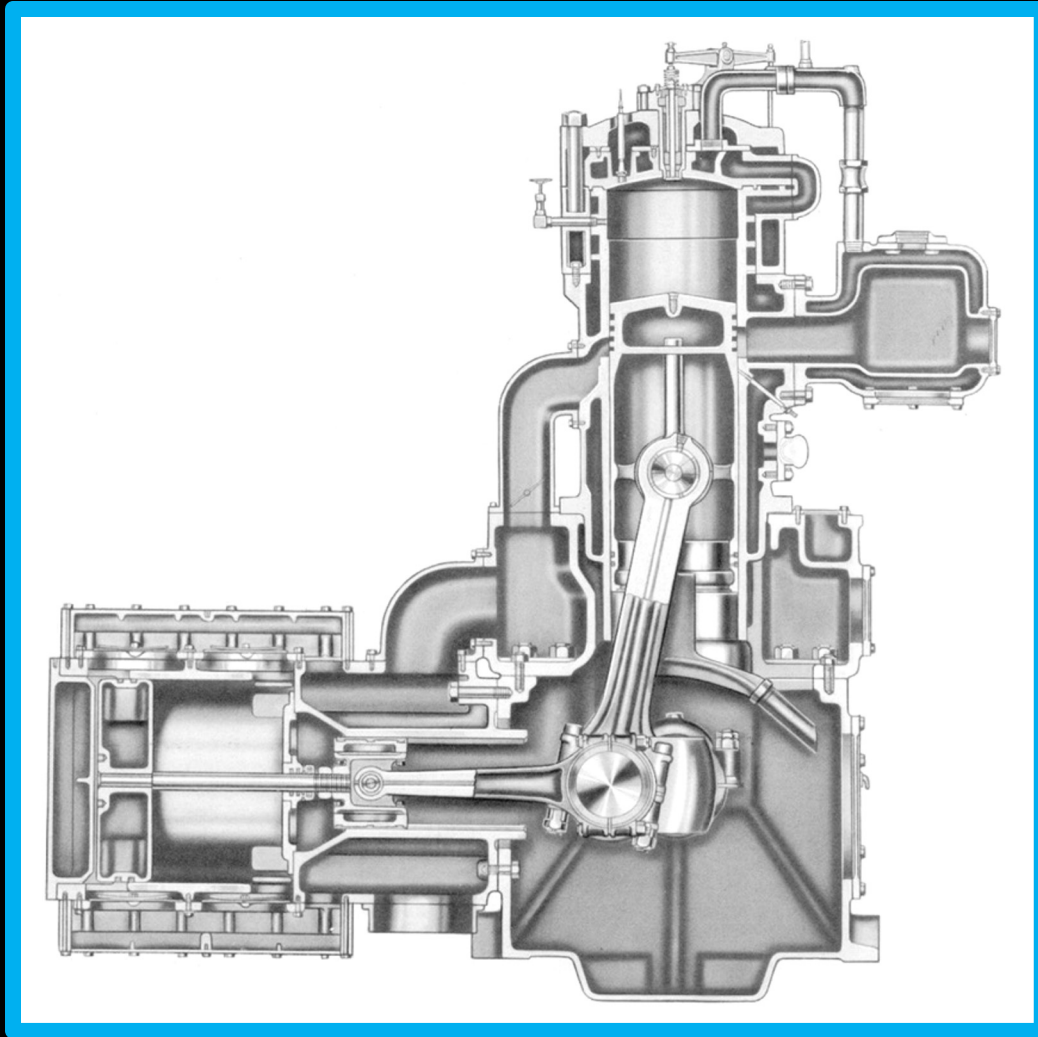

Integral types have a common crankshaft shared between the power cylinders and compressor cylinders.

Dresser-Rand (Clark) RA, 2stroke integral gas engine & compressor with non-articulated power connecting rods

## 2 Stroke Integral (Vee & Inline)

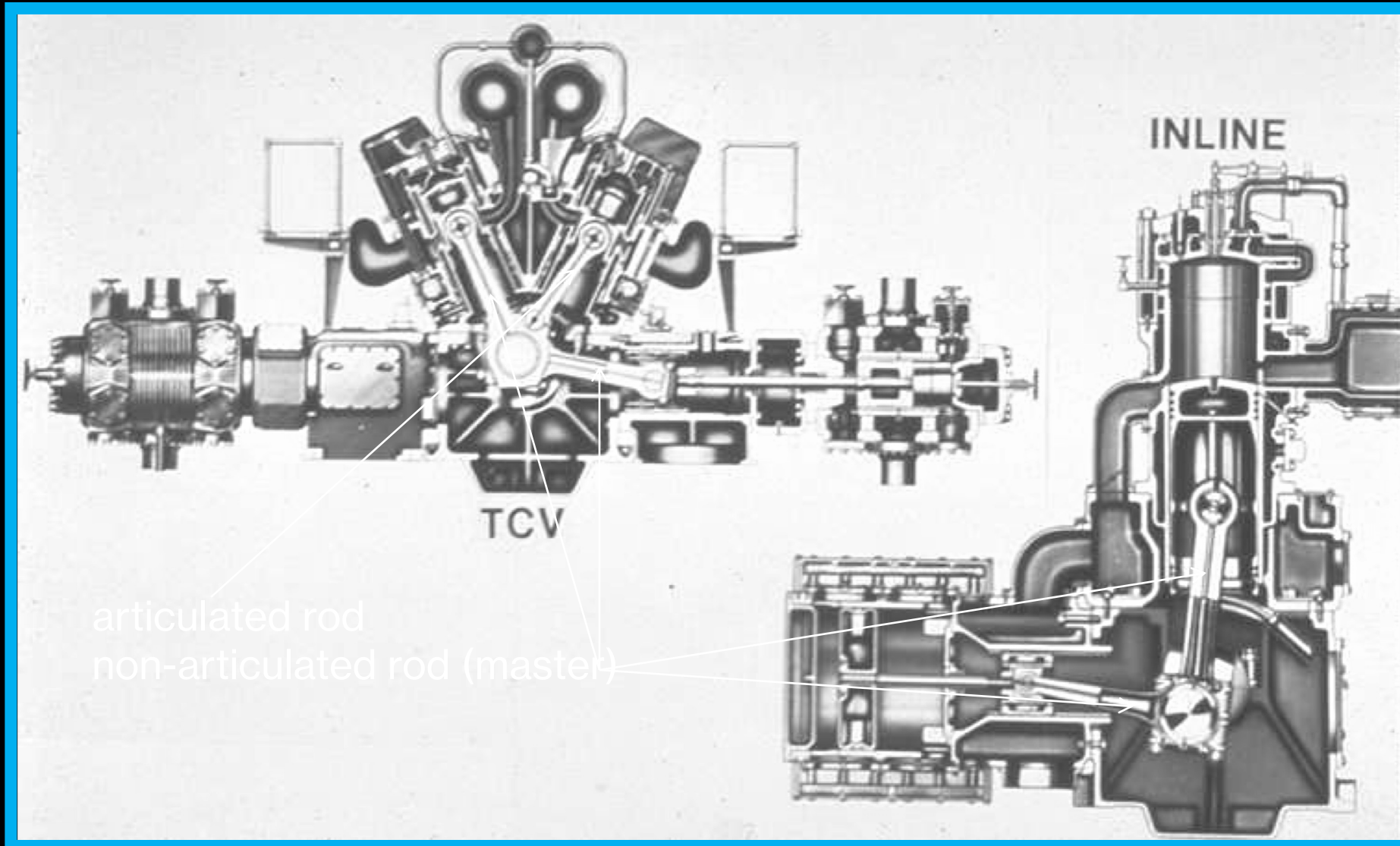

# Combustion Types (2 & 4 Stroke)

- Normal
- No Ignition
- Early Ignition
- Late Ignition
- Detonation
- Pre-ignition
- Intermittent Firing

# Normal Combustion Requirements

- Correct amount of fuel with the proper BTU
- The right amount of air at the right pressure and temperature to control the combustion rate
- Proper amount of ignition energy at the right degree of crankshaft rotation

# Normal Combustion

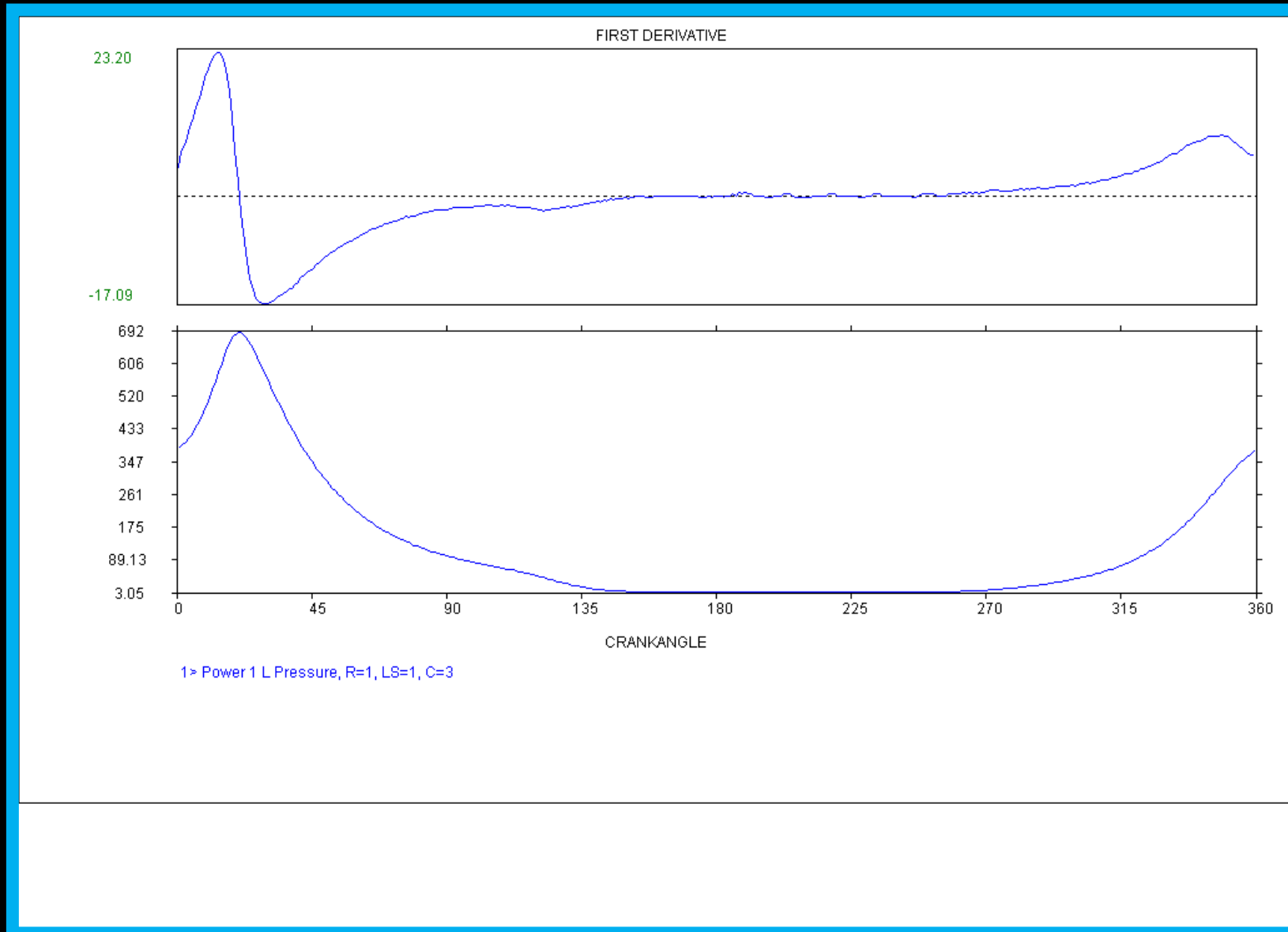

# No Combustion

- The air/fuel charge does not ignite and there is no pressure rise except from the compression process
- Negative horsepower results due to pumping losses
- Caused by problems with air, fuel, foreign material or defective ignition

# No Combustion

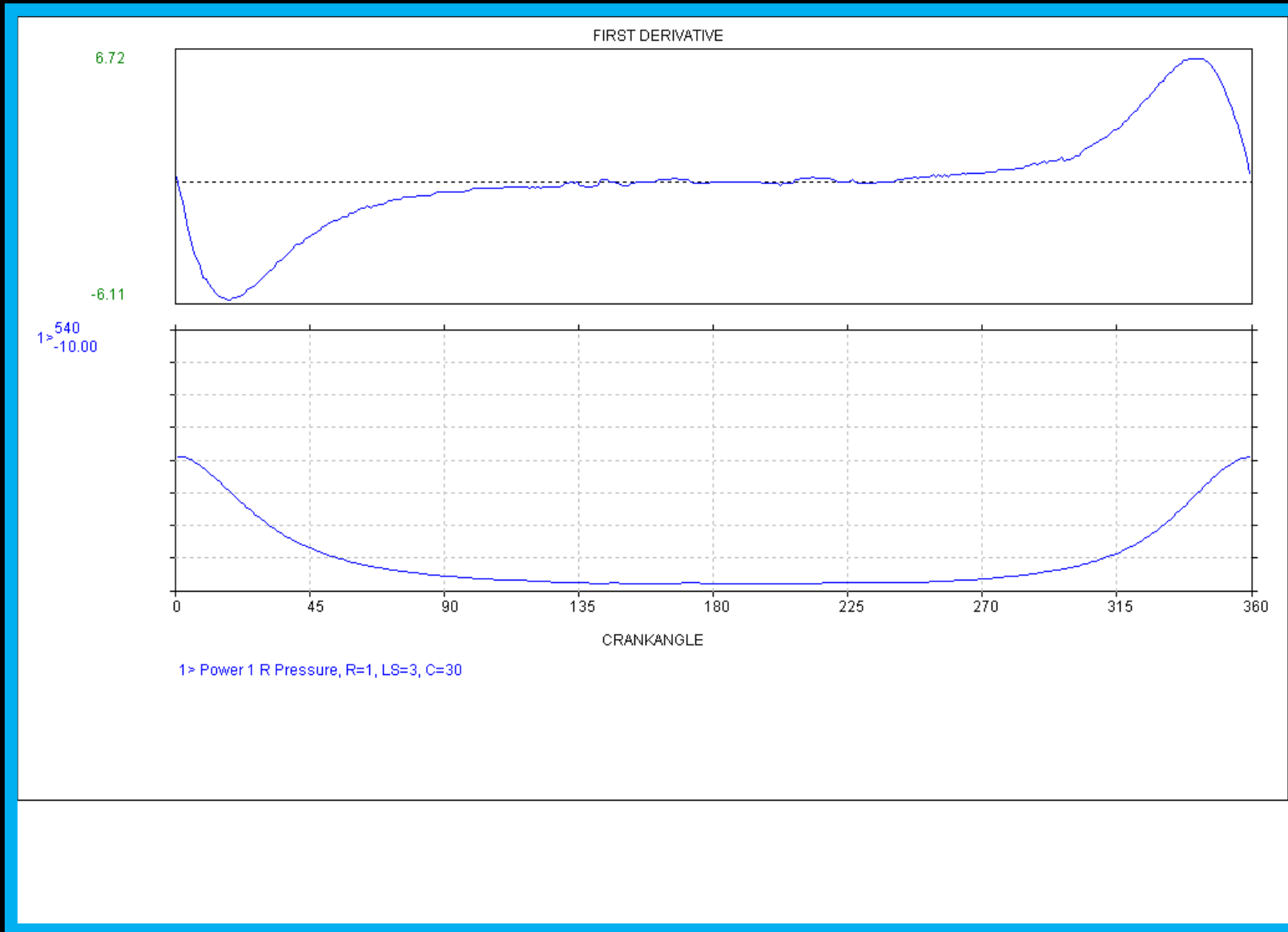



# Electronics Evolve

- Beta-Trap
- Windrock 6310 CA
- Windrock Autobalance™
- MMS Snapshot®
- Hoerbiger/Cooper Hyperbalance III™
- MMS ProBalance® / ProBalance® Plus



# Balancing Methods

# Peak Firing Pressure Balancing

- **Peak Firing Pressure (PFP)** is the most common balancing method – probably due to the history of balancing – it was easy to measure.
- It is accomplished by measuring the firing pressures of all the cylinders, calculating the mean of those pressures, and adjusting the firing pressures as close to that mean pressure as possible.

# Peak Pressure Ratio Balancing

- **Peak Pressure Ratio (PPR)** is a method suggested in EPPL / SWRI / DOE study in 2008. In this method, the PFP and the unfired Compression Pressure ( $C_p$ ) of each cylinder is measured.
- The compression pressure is an indication of how much air is trapped in the cylinder. Since we cannot change that, by inputting the proper amount of fuel into each cylinder, we can control the equivalence ratio, which influences the combustion process.

# Peak Pressure Ratio Balancing

- The PFP is divided by the  $C_p$  establishing the PPR.

$$PPR = PFP \div C_p$$

- Multiplying the Average PPR by the individual cylinder  $C_p$ 's generates the target PFP for that cylinder.
- Research has proven that utilization of the PPR method reduces  $NO_x$ , COV's and associated crankshaft stresses induced by rapid variations in angular velocities imparted by unbalance and misfires\*.

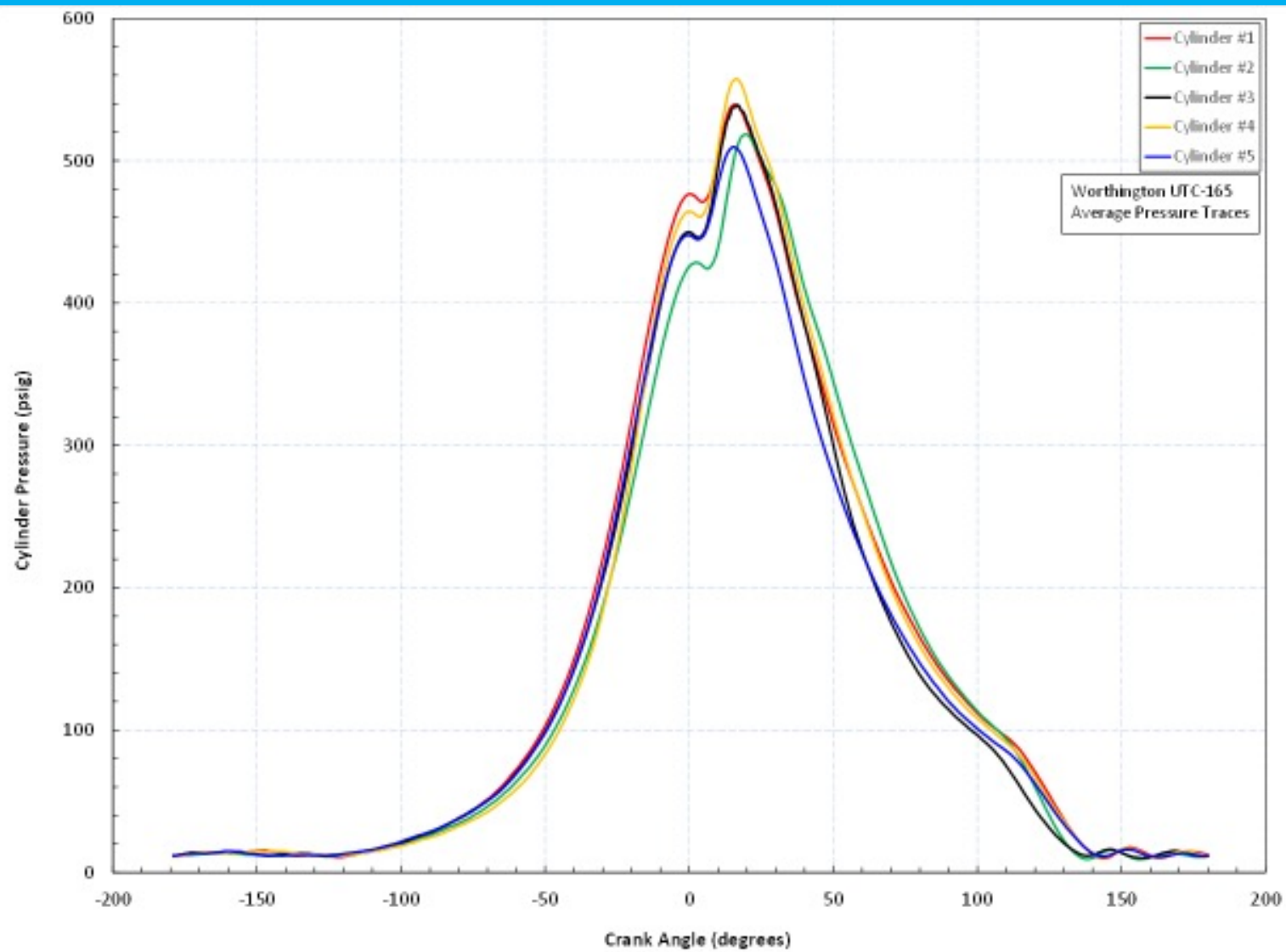

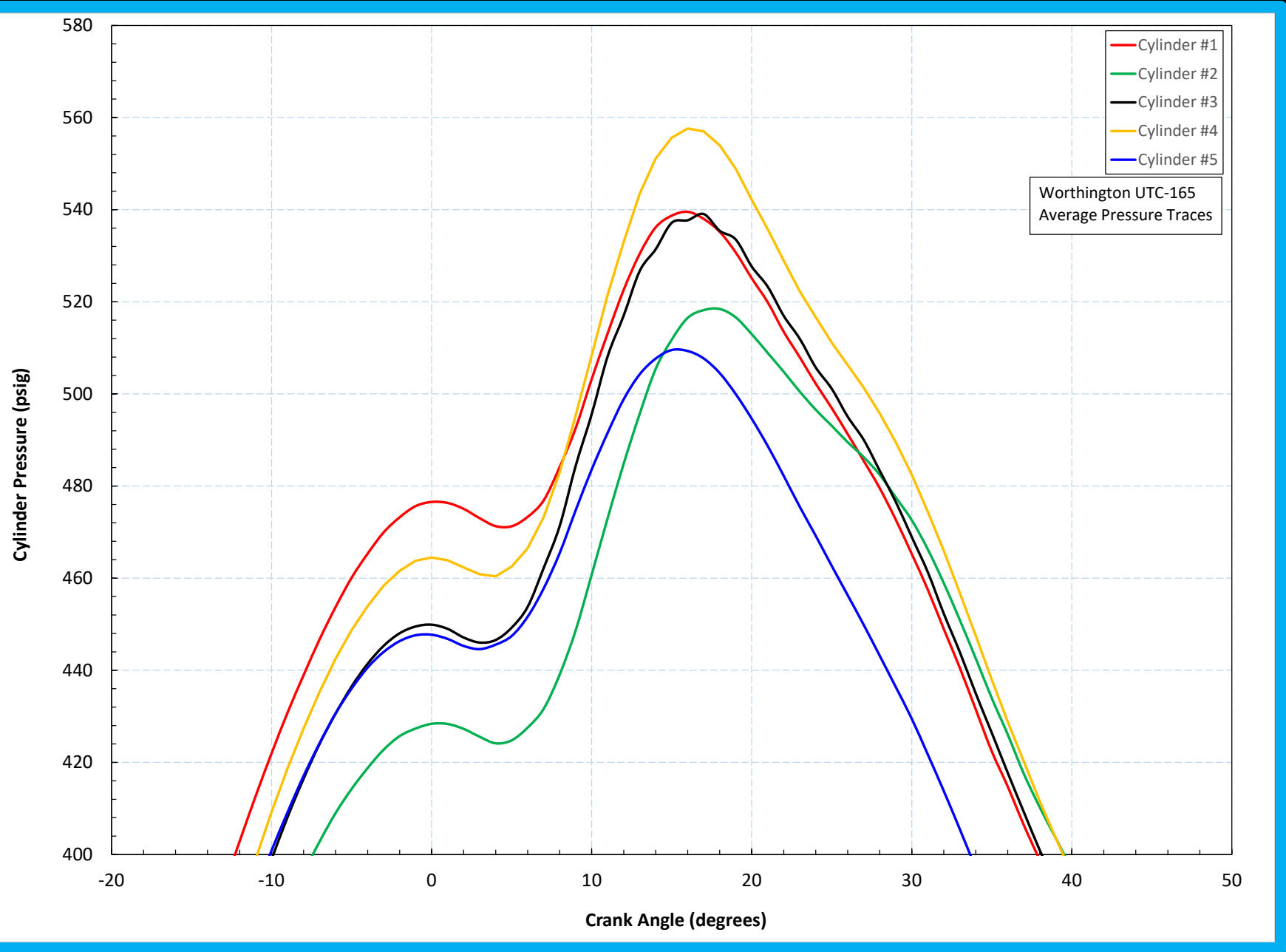

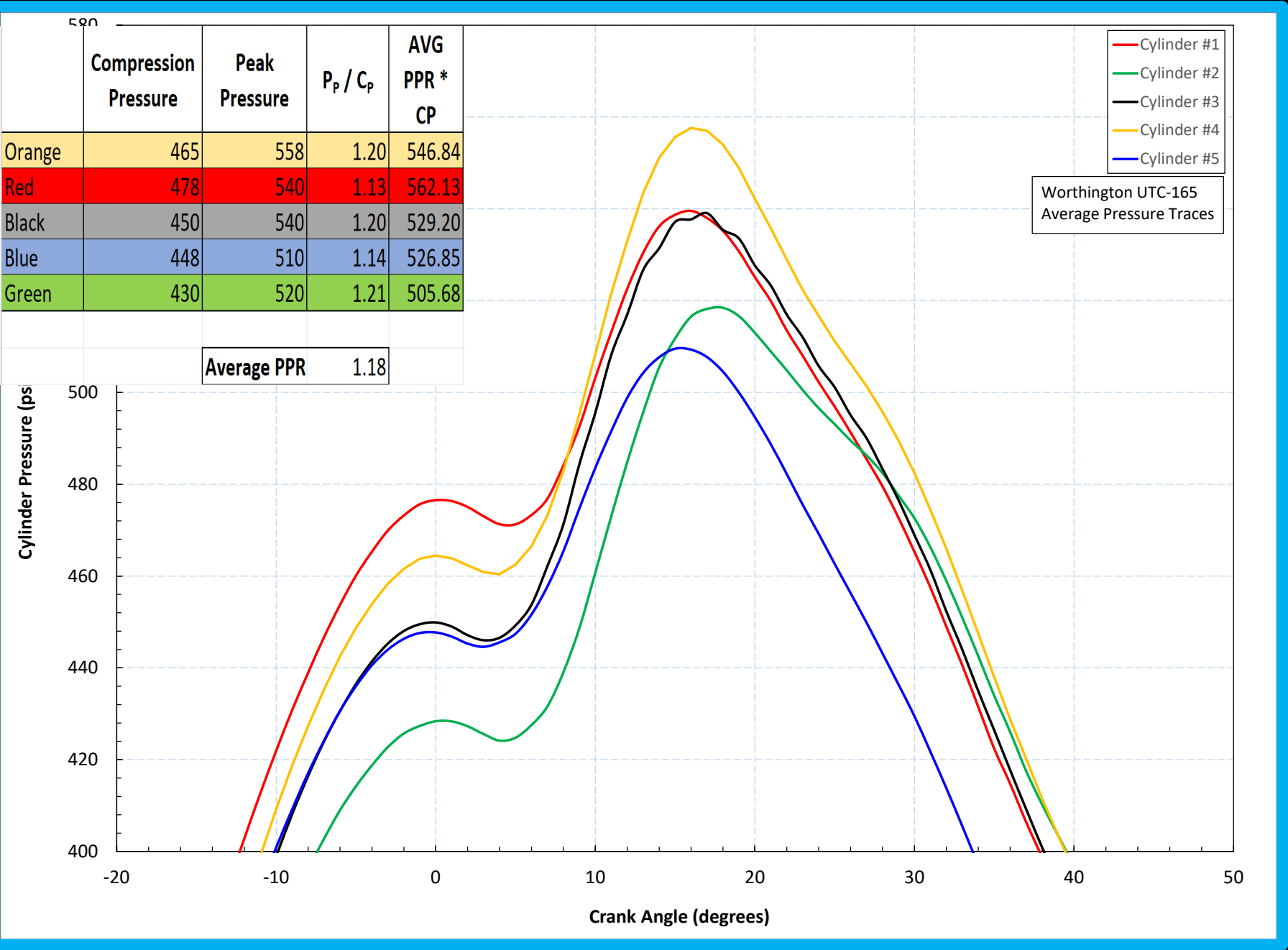



# PFP to PPR Comparison

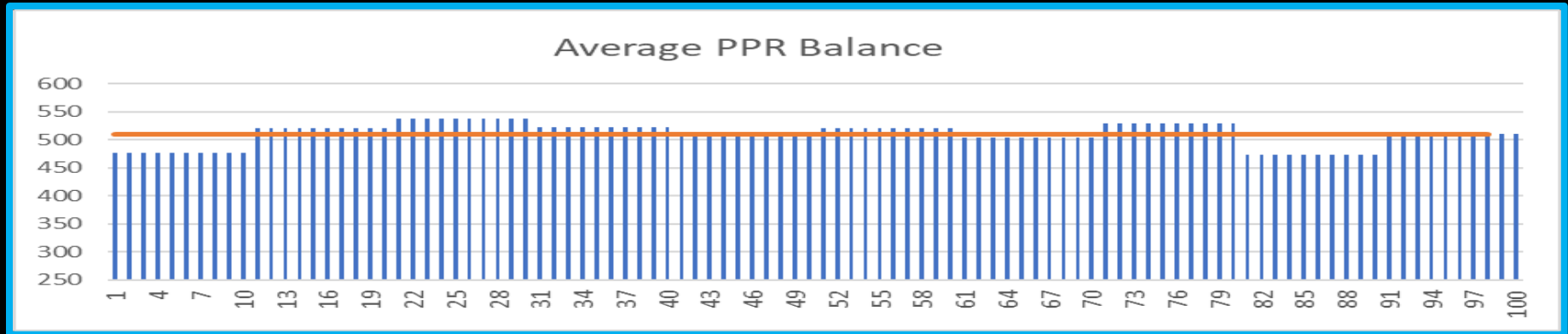
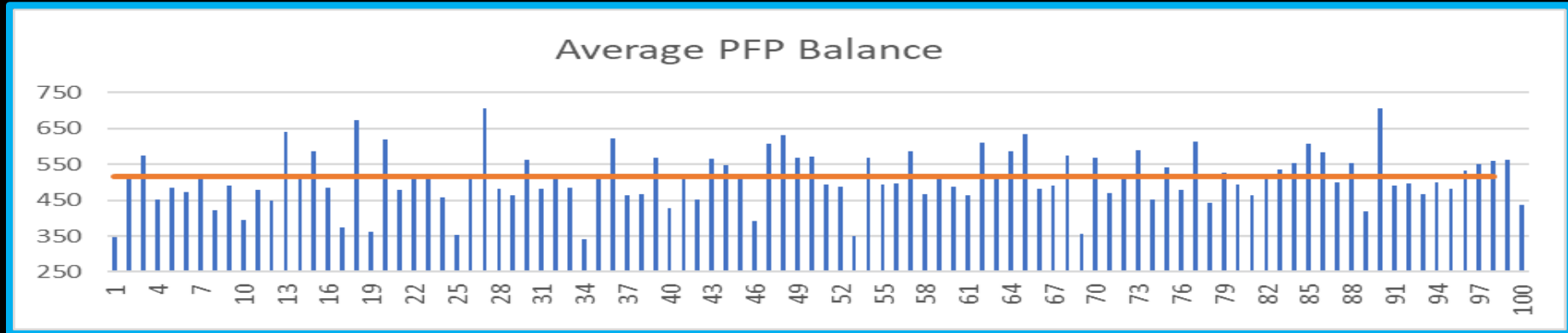

# Next Steps

- Education – End users need to understand the benefits of PPR.
- Implementation – Some systems have the ability to utilize PPR in their balancing methodology.



**Thank you**

**Questions?**